



HOSHIZAKI

CERTIFICATION



HACCP International



ISO9001

DCM-80LS-P-HC ICE & WATER DISPENSER



Key Features



Eco-Friendly Refrigerant

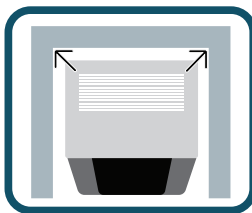

Perfect fit

There are no exhaust outlet on the left and right sides and the back, so it can be placed close to the wall.



Hygienic design

This Lever type of ice dispenser prevents touching the lip of a glass.



Easy for daily cleaning

Draining board can be removed



Easy for maintenance

Notify when parts should be replaced

Hoshizaki DCM series are ice/water dispensers producing high-quality servings of cubelet ice and/or water. The three steps of quality ice production, protected ice storage, as well as quick service of ice are all combined in one device – with the help of only one button your refreshment is ready in seconds. With DCM DISPENSERS the user can select from these options:

- » Cubelet ice only
- » Cubelet ice and water
- » Water only



Dimensions & Specifications

TOP

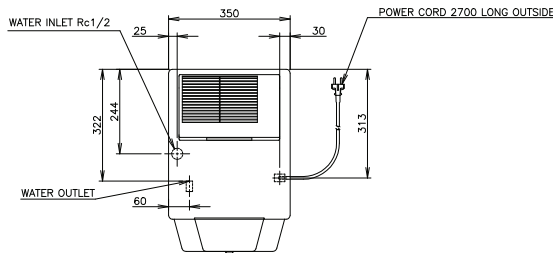

ICE SHAPE

Cubelet
Compressed Flake Ice

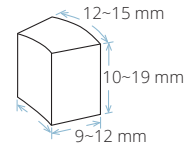

FRONT

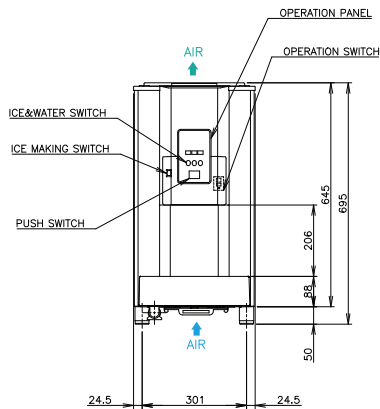

RIGHT SIDE

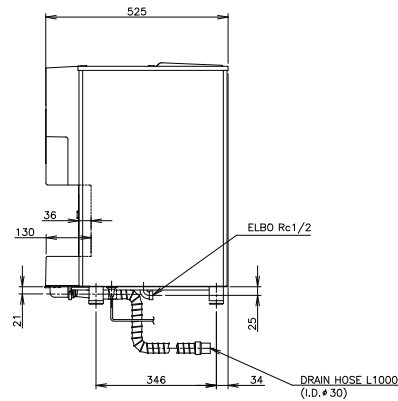

MODEL		DCM-80LS-P-HC
ICE SHAPE		Cubelet (Compressed Flake Ice)
POWER SUPPLY		1 Phase 220-230V 60Hz Capacity: 0.39kVA (1.7A)
AMPERAGE		1.5A Started: 7.3A
ELECTRIC CONSUMPTION		294W
HEAT REJECTION	(AT32°C / WT21°C)	610W
ICE PRODUCTION PER 24H	(AT10°C / WT10°C)	90kg
	(AT21°C / WT15°C)	74kg
	(AT32°C / WT21°C)	59kg
ICE DISPENSING RATE (40G / CUP)	(AT10°C / WT10°C)	Approx. 146 cups / h
	(AT21°C / WT15°C)	Approx. 131 cups / h
	(AT32°C / WT21°C)	Approx. 117 cups / h
STORAGE CAPACITY		Approx. 1.9kg
WATER CONSUMPTION PER 24H	(AT32°C / WT21°C)	50L
REFRIGERANT		R290 / 75g
OUTSIDE DIMENSIONS		350mm(W) x 525mm(D) x 695 (- 710)mm(H)
PACKAGE		Carton 400mm(W) x 581mm(D) x 749mm(H)
WEIGHT		41kg (Gross 44kg)
OPERATING CONDITIONS		Ambient Temp:5-40°C, Water Supply Temp:5-35°C
		Water Supply Pressure: 0.05-0.78MPa
		Voltage Range: Rated Voltage±4%



HOSHIZAKI

HOSHIZAKI PHILIPPINES CORPORATION

Unit No. GB-2, G/F Agustin 1 Bldg., # 28 F. Ortigas Center, Pasig City, Philippines 1605

TEL +632 8839 2861 | <https://hoshizaki-sea.com/>

